

## Allstar Tactical stays *On-target* with RhinoCAM<sup>®</sup>

**Allstar Tactical**, located in Rochester New York, began in 2008 as an “over the counter” firearms dealer, owned and operated by Mike Centola. Mike quickly expanded the business to building custom rifles for his friends and acquaintances in the local gun clubs as well as for clients from **Allstar Tactical’s** online store front at <https://www.allstartactical.com/>.



[Click here to see the AR-15 Muzzle Break in Action](#)

With a degree in Electrical Engineering,

Computer Systems Engineering, and a masters in IT, Mike is also self-taught in Mechanical

Engineering and has experience in the use of SolidWorks<sup>®</sup>, Rhino and RhinoCAM<sup>®</sup>

*“I’m also trained in MasterCAM<sup>®</sup> but I’m not a fan. It didn’t flow right for me and it seemed very “old school.” I really prefer the ease of setting up and getting stuff going in RhinoCAM. I think it hands down has a better interface and is way easier to use.”*

## Today at Allstar Tactical

Today, **Allstar Tactical** is centered almost exclusively on the AR-15 assault rifle platform and the bolt-action Remington 700. They also carry a full line of rifles. Currently they are focused on a line of muzzle breaks which can be seen in action on the AR-15 in the image and video link above.



**Allstar Tactical’s line of muzzle breaks left to right:**  
(Corkscrew Flash Hider, DELTA AR15 Muzzle Brake, HEXCON1 Compensator)

## The HEXCON0 Muzzle Break/Compensator

The new *HEXCON0* from **Allstar Tactical** is their latest Muzzle Break (also referred to as a Recoil Compensator) designed for AR-15 assault rifle. The design of the muzzle break is to redirect the propellant gasses of each fired round to help counter the recoil and the unwanted rising of the barrel during rapid firing of the AR-15.

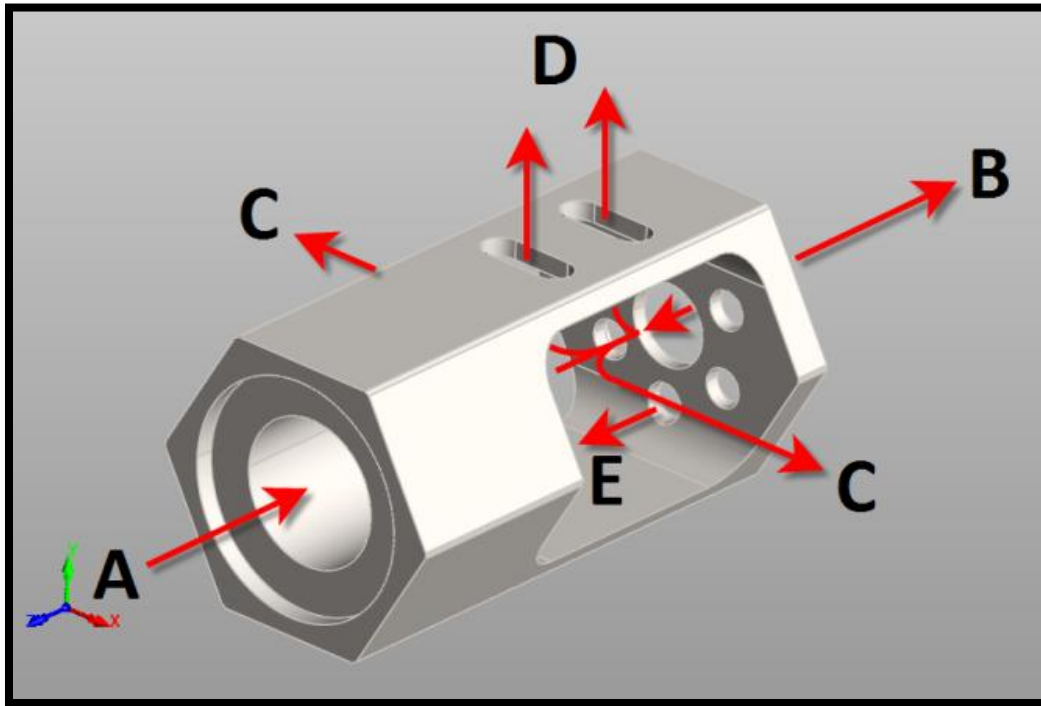

Propellant Gas Dispersion from the HEXCON0 Muzzle Break/Compensator

The illustration at above and the line items below provide a basic description of how the *HEXCON0* works when threaded onto the end of the AR-15 barrel:

- A. The fired round leaves the barrel of the AR-15.
- B. The round passes through the *HEXCON0* and on to its intended target.
- C. Propellant gasses from the discharged round are quickly and evenly directed to the right and to the left of the barrel.
- D. A percentage of the propellant gasses are also directed upward to help counter the upward rise of the barrel.
- E. Upon exiting the barrel, additional propellant gasses are evenly distributed through a pattern of holes on the external face of the *HEXCON0* providing additional stabilization and accuracy.

## Toolpath Strategy for the HEXCON0

All of the 2½ Axis toolpaths needed to machine and post the *HEXCON0* to **Allstar Tactical's** *MILLTRONICS-Centurion 6* controller are included in RhinoCAM. Using 416 Stainless hexagon bar stock that meets the external dimensions needed, 4 different setups are then generated in RhinoCAM. Each is described in detail below:

### Setup 1: Facing, Pocketing, Deep Drill & Tap

This first setup machines the end of the *HEXCON0* that mounts to the barrel of the AR-15 indicated as "A" in the illustration above. The setup is aligned to Rhino's WCS (World Coordinate System). A facing operation is first to machine down to the finished dimension using a 1" Dia. Flat End Mill, 25% Stepover, Depth/Cut set to 0.1 and a straight plunge Entry/Exit motions.

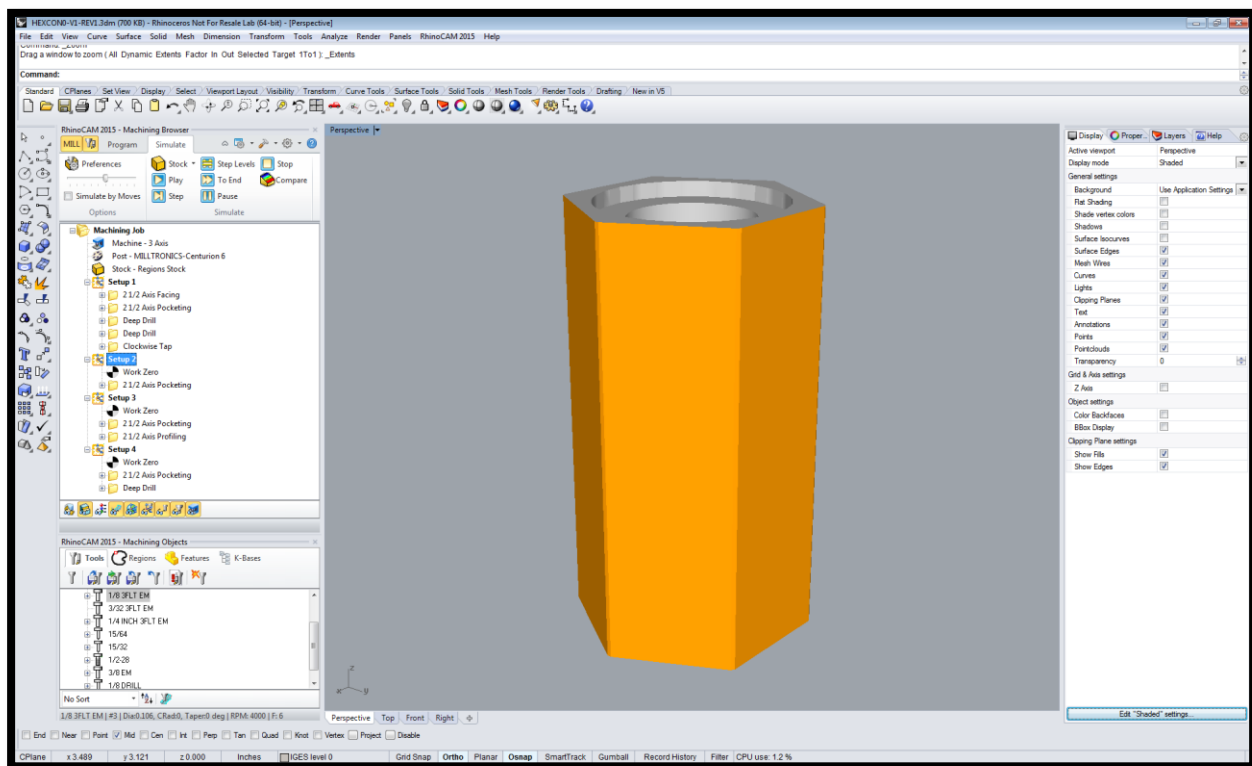

Setup 1: Facing, Pocketing, Deep Drill & Tap

This is followed by a 0.125 deep pocketing operation using a 0.250" Dia. flat end mill, a 0.05" depth per cut and helical engage and linear retract motions. This is followed by two Deep Drill operations. The first, at 0.234" Dia. passes completely through the stock and cuts at peck increments of 0.1". The second being 0.468" Dia. and a depth of 0.75". These are followed by a ½-28 clockwise tap operation. These threads match the barrel on the AR-15.

## Setup 2: Pocketing

This setup machines the two slots identified as “D” in the illustration above, on the top of the HEXCON0 using a pocketing operation and 0.125” Dia. flat end mill and linear engage and retract motions.

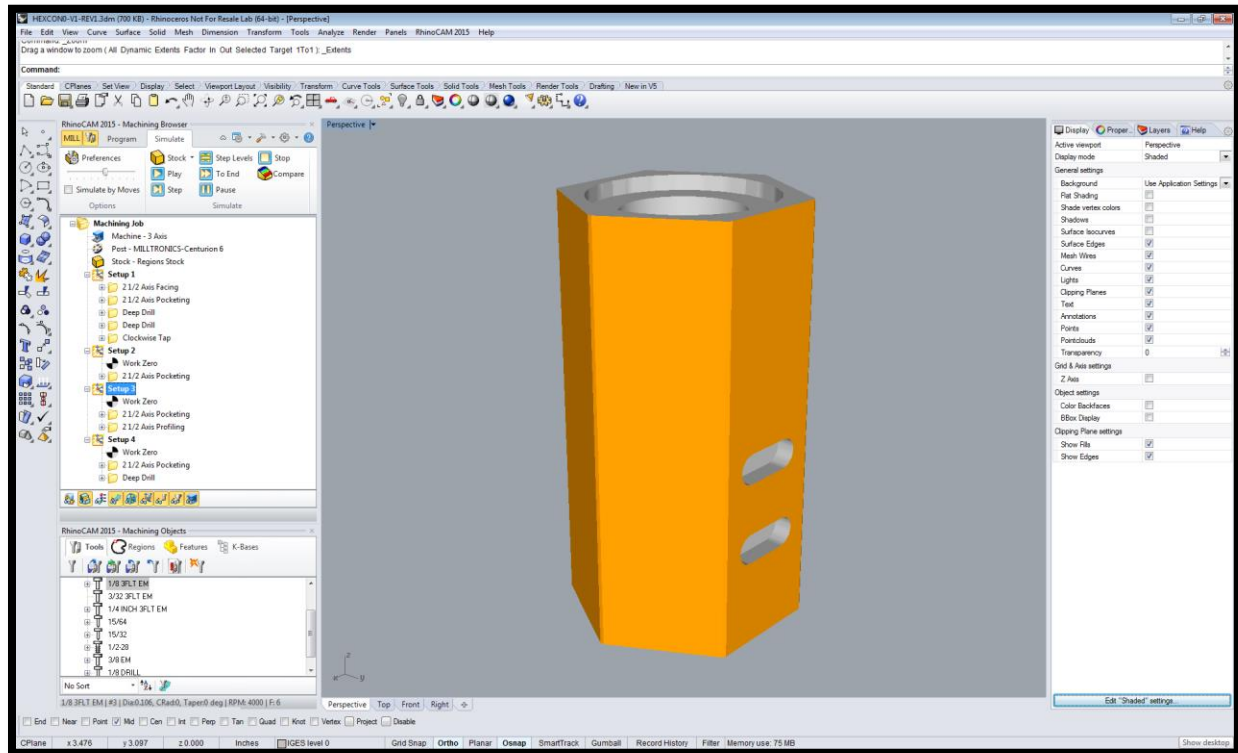

Setup 2: Pocketing

## Setup 3: Pocketing & Profiling

In this next setup, the large pocket that passes completely through the *HEXCON0* from right to left indicated as “C” in the illustration above is machined. A 0.375” flat end mill is used with a helix approach and linear retract motions. The pocket operation leaves 0.025” of stock on the side walls. This is followed by a profiling operation using a 0.25” flat end mill that finishes the pocket to the part’s surfaces.

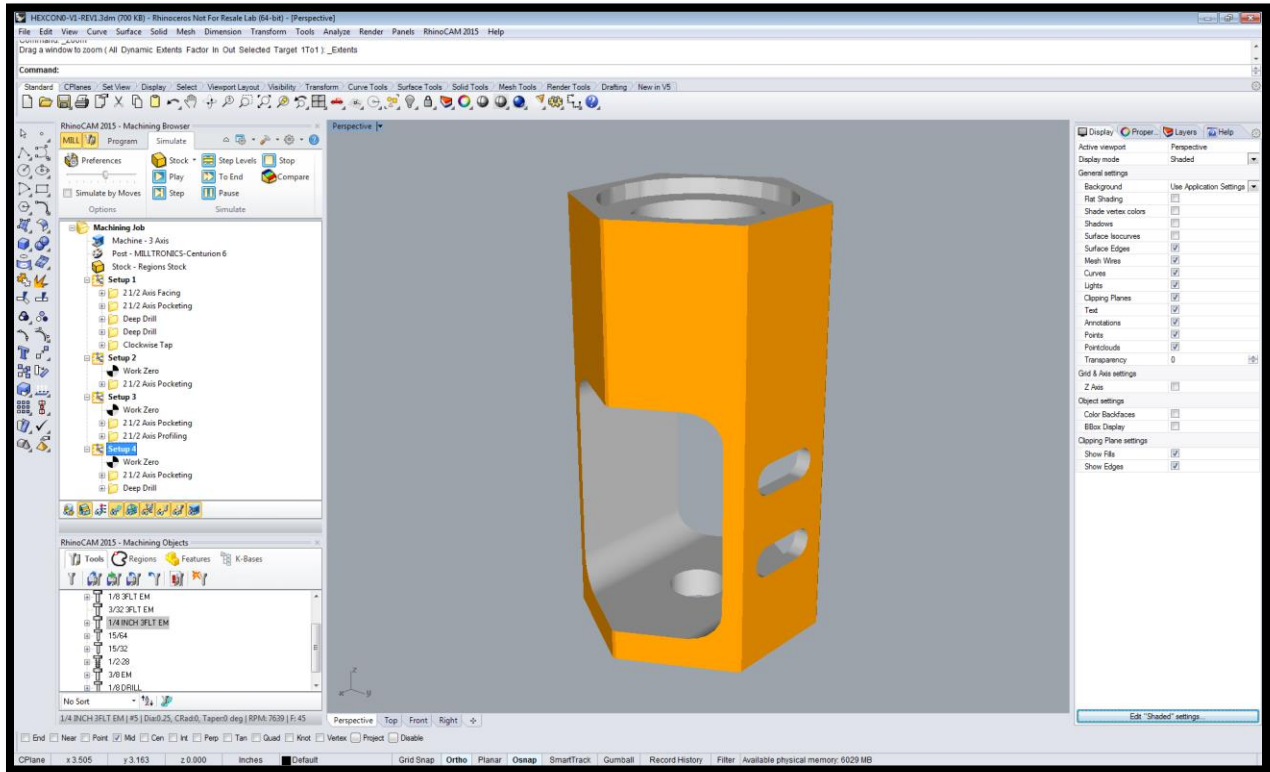

## Setup 3: Pocketing & Profiling

### Setup 4 Pocketing & Deep Drill

This final setup first machines a 0.075" deep hexagon shaped pocket (not shown) on the opposite end of the *HEXCONO* that serves as the extended barrel of the AR-15 indicated as "B" in the illustration above. This is followed by deep drilling a pattern of six holes using 0.125" Dia carbide tipped drill using step increments of 0.0125".



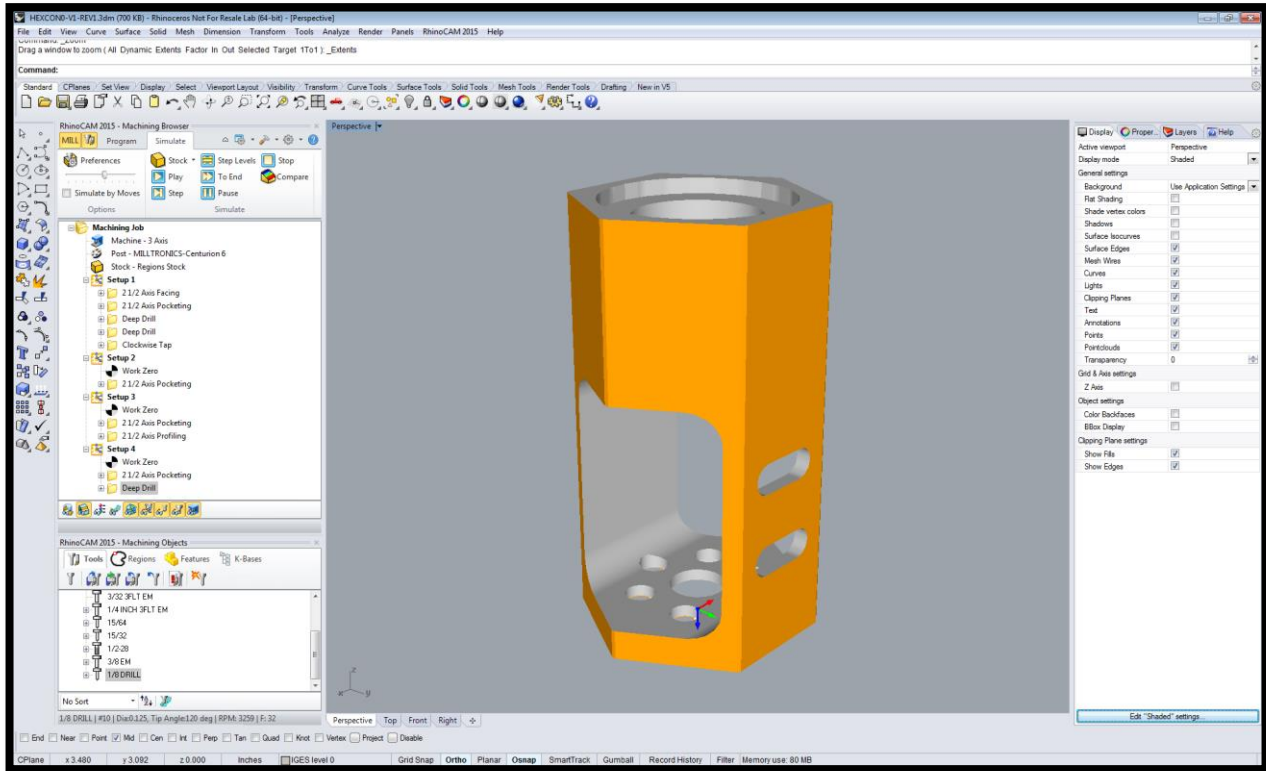

Setup 4: Pocketing & Deep Drill

## More about Allstar Tactical

You can see more of Mike's work at **Allstar Tactical** by visiting the following web and social media sites:



## More about RhinoCAM

RhinoCAM is available in 4 different configurations (**Standard**, **Expert**, **Professional** and **Premium**). The part shown here was programmed using the **Professional** configuration. Here are some additional details about each of the available configurations. [Click here](#) for the complete features list.

- **RhinoCAM Standard:** Basic 2 & 3 Axis plus Hole Making machining strategies on a single setup with toolpath animation and cut material simulation.
- **RhinoCAM Expert:** Includes the Standard configuration plus 4 Axis machining strategies, advanced cut material simulation and tool holder collision detection.
- **RhinoCAM Professional:** Includes the Standard and Expert configuration plus advanced 3 Axis machining strategies, 5 Axis indexed machining, machine tool simulation, graphical toolpath editing and a host of other features.

- **RhinoCAM Premium:** Includes the Standard, Expert and Professional configurations plus 5 Axis simultaneous machining strategies.

To read more about **RhinoCAM** and other MecSoft Corporation products including screen images, resources and features lists, please visit our [Product page](#). You can also download our products for a test drive by visiting our [Download Demo Products](#) page.